

Hydraulic Spike Driver 910169 Operating Manual



Hydraulic Spike Driver

910169

Record of Changes

Rev No.	Date	Description of Changes
Rev 1	12.2016	Initial release.
Rev 2	6.2022	Branding Update
Rev 2.1	1.2023	Format and Layout Changes

Table of Contents

Section 1: Overview and Safety	5
Hydraulic Spike Driver Overview.....	5
Environmental Protection	5
Safety Information	5
Safety Terms	6
Machine Use and Safety Precautions	6
Section 2: Specifications and Installation.....	7
Unpacking Instructions.....	8
Tool Preparations	8
Hose Requirements	8
Hose Types	8
Hydraulic Hose Recommendation.....	9
Hydraulic Fluid Recommendation	9
Tool Connecting Procedures.....	10
Disconnecting Hoses.....	10
Section 3: Tool Operation	11
Personal Protective Equipment	11
Operation.....	11
Shut-Down Procedures	11
Section 4: Maintenance.....	12
Trouble Shooting	13
Section 5: Parts and Service Support	14
Hydraulic Spike Driver Assembly and Parts List.....	15
Section 6: Warranty Terms and Conditions	20

This page was intentionally left blank.

Section 1: Overview and Safety

Hydraulic Spike Driver Overview

Racine Railroad Products designs and manufactures equipment primarily for the repair and new construction of rail and railroad tie track maintenance.

The Racine Railroad Products Hydraulic Spike Driver is a portable, remotely powered, handheld power tool designed for track rail fastening. The Racine Hydraulic Spike Driver accommodates rail and tie plate spikes uses a high impact reciprocating ram to finish inserting steel spikes into wooden cross-ties after spikes are manually started.

Do not use this machine for other than its intended purpose.

Please read these instructions when using this tool, which can only be used for the specified purpose. Failure to do so could result in personal injury or equipment damage. This instruction manual should be kept throughout the life of the tool.

The operator of this tool should:

- Have access to this operation instruction.
- Read and understand this operation instruction.

Note: Information in this document is subject to change without notice.

Environmental Protection



Comply with relevant national waste disposal laws and regulations. Waste electronic devices cannot be treated as household waste.

Equipment, accessories, and packaging shall be recyclable.



Don't throw the discarded equipment in trash cans.

Safety Information

For safe installation and operation of this equipment, carefully read and understand the contents of this manual. Improper operation, handling, or maintenance can result in equipment damage and personal injury.

Only trained and authorized personnel should be allowed to operate this machine. In addition, all personnel at the worksite should be aware of the safety concerns and their individual responsibilities prior to working this machine.

Please read and comply with all the safety precautions in this manual **before** operating this machine. Your safety is at risk.

Safety Terms



DANGER indicates a hazardous operating procedure, practice, or condition. If the hazardous situation is not avoided death or serious injury will occur.



WARNING indicates a hazardous operating procedure, practice, or condition. If the hazardous situation is not avoided death or serious injury could occur.



CAUTION indicates a potentially hazardous operating procedure, practice, or condition. If the hazardous situation is not moderate or minor injury could occur.

Machine Use and Safety Precautions



Failure to follow safety precautions when operating this equipment can result in serious injury or death to the operator or other persons in the area.

Observe the following precautions whenever you are operating, working on or near this equipment.

Do not make any modifications without authorization or written approval from Racine Railroad Products. Replace all Racine Railroad Products and OEM parts with genuine Racine Railroad Products and OEM parts. Using non-OEM parts may compromise the safety of the machine.

Do not wear loose clothing, jewelry, radio belts, etc., when operating, working on or near this equipment. They can be caught in moving parts and may result in severe injury.

Always wear appropriate personal protective clothing when operating this equipment: e.g., orange safety vest, hard hat, safety glasses with side shields, hearing protection, steel-toed safety boots, leather gloves, dust respirator, etc.

Always lift heavy objects with the knees and legs, not the arms and back.

Always keep hands, arms, feet, head, clothing, etc., out of the operating area and away from all rotating or moving components when operating, working on or near this machine.

Always make sure that all guards, covers, belts, hoses and operating components are in good working order and that all controls are in the appropriate position before starting the engine.

Always make sure that all safety equipment installed properly and are in good working order. Do not operate the machine until unsafe conditions have been corrected.

Always operate in a well-ventilated area and make sure that the air filters, air filter covers, and muffler are in good condition.

Always keep the machine clean and free of debris. Operate the machine in a safe and responsible manner. Exercise caution when fueling, working on or near rotating or moving components, hot components and fuel systems. Be aware of potential fire hazards and prevent sparks, exhaust, etc., from starting fires on the machine and/or work area.

Always comply with all instructions provided on any decals or placards installed on the machine and with any relevant amplifying information provided in this manual or other general operating procedures.

Always disconnect the power source and make sure that all controls are in a safe position and install all appropriate locking and safety devices before doing any of the following:

- Lubricating
- Adjusting
- Installing Tooling
- Making Repairs
- Performing Service

Section 2: Specifications and Installation

Hydraulic System:..... Open Center
 Length:..... 30.50 in. (~77.0 cm)
 Width:..... 18.00 in. (~75.7 cm)
 Height, Work Mode: 6.00 in. (~15.24 cm)
 Weight:..... 88 lbs. (~39.8kg)

Mechanical Data

Hydraulic Motor:
 Maximum Flow:..... 10 gpm (~38 lpm)
 Maximum Pressure:..... 2000 psi (~140 bar)
 Full Bypass Setting: 2250 psi (~157 bar)

Hydraulic fluid requirements:

Viscosity (Fluid Thickness)

U.S.A.	METRIC
50° F 450 SSU Max.	10° C 95 Centistokes
100° F 130-200 SSU	38° C 27-42 C.S
140° F 85 SSU Min.	60° C 16.5 C.S., Min.

Pour Point 10° F/23° C Minimum (for cold startup)
 Viscosity Index (ASTM D 2220) 140° F Minimum
 Demulsibility (ASTM D-1401) 30 Minutes Maximum
 Flash Point (ASTM D-92) 340° F/171° C Minimum
 Rust Inhibition (ASTM D-665 A & B) Pass
 Oxidation (ASTM D943) 1000 Hours Minimum
 Pump Wear Test (ASTM D2882) 60 mg Maximum
 Recommended hose size: .500 inch/12mm I.D. up to 50 ft./15m long
 Recommended hose size: .625 inch/16 mm I.D. up to 100 ft/30 m long

Unpacking Instructions

Upon receiving your Hydraulic Spike Driver promptly remove it from the shipping container. Always keep top side of container up. Inspect unit for damage which may have incurred during shipping and report it to carrier for claim.

Tool Preparations

The Hydraulic Spike Driver may require some assembly before use. The machine should receive an in-service inspection before initial operation. If the tool is used in cold weather, preheat the hydraulic fluid by running power source at low engine speed.

Fluid temperature should be at or above 50° F/10° C (400-ssu / 82 centistroke) before use, when using recommended fluids. Using too thick of fluid may result in tool damage.



WARNING Never stick foreign objects, fingers, or other extremities into moving mechanism. Failure to follow these instructions may lead to severe personal injury or tool damage.

Hose Requirements

It is not often necessary or advisable to use long hoses. All hoses must have an oil resistant inner surface and an abrasion resistant outer surface. Each hose must have male pipe ends for most application.

Longer hoses can be used when necessary but can affect the operation of the tool due to resistance in the hose. If small diameter or long hoses are used, or if restrictive fittings are connected to the supply and return ports, the pressure required to push the fluid through the system and back to the tank will be higher. This will reduce tool power.

Important: Oil should always flow from the male coupler through the female coupler.

Note: The pressure increases in uncoupled hoses left in the sun. This may make them difficult to connect. When possible after use, connect the free ends of the operating hoses together.

Hose Types

Hydraulic hose types authorized for use with the Hydraulic Spike Driver are:

1. **Labeled and certified non-conductive.**
 - This is the only hose authorized for use near electrical conductors.
 - Constructed of thermoplastic or synthetic rubber inner tube, synthetic fiber braid reinforcement, and weather resistant thermoplastic or synthetic rubber cover.
2. **Wire braided** (conductive)
 - This hose is conductive and must **never** be used near electrical conductors.
 - Constructed of synthetic rubber inner tube, single or double wire braid reinforcement, and weather resistant synthetic rubber cover
3. **Fiber braided** (not certified or labeled non-conductive)
 - This hose is conductive and must **never** be used near electrical conductors.
 - Constructed of thermoplastic or synthetic rubber inner tube, synthetic fiber braid reinforcement, and weather resistant thermoplastic or synthetic rubber cover.

The rated working pressure of the hydraulic hose must be at least 175 bar (2500 psi).

Hydraulic Hose Recommendation

Hydraulic Hose Recommendation								
Flow Per Circuit		Length Each Hose		Use	Inside Diameter		SAE Spec Hose (Wire Braid)	SAE Spec Hose (Fiber Braid)
GPM	LPM	Feet	Meter		Inch	MM		
5 to 8	19 to 30	To 50	To 15	Both	1/2	13	SAE 100R1-8	100R7-8
5 to 8	19 to 30	51 to 100	15 to 30	Both	5/8	16	SAE 100R2-10	SAE 100R8-10
5 to 8	19 to 30	100 to 300	30 to 90	Pressure Return	5/8 3/4	16 19	SAE 100R2-10 SAE 100R1-12	SAE 100R8-10 SAE 100R7-12
9 to 12	34 to 45	To 50	To 15	Both	5/8	16	SAE 100R2-10	SAE 100R8-10
9 v 12	34 to 45	51 to 100	15 to 30	Pressure Return	5/8 3/4	16 19	SAE 100R2-10 SAE 100R3-12	SAE 100R8-10 SAE 100R7-12
9 to 12	24 to 45	100 to 200	30 to 60	Pressure Return	3/4 1	19 25.4	SAE 100R2-12 SAE 100R1-16	SAE 100R8-12 SAE100R7-16

The rated working pressure of the hydraulic hose must be at least 2500 psi / 173 bar.

Hydraulic Fluid Recommendation

Inspect hoses for cuts, crushing, leaks, or abrasion, which may be a safety hazard or reduce fluid flows.

The following fluids work well over a wide temperature range at startup, allow moisture to settle out, and resist biological growth likely in cool operating hydraulic circuits.

Others that meet or exceeds the specifications of these fluids may also be used.

Type	Hydraulic fluid
Chevron	Clarity AW 15032
Exxon	Univis J 32
Mobil	D.T.E. 13M
Gulf	Harmony AW-HVI-150-32
Shell	Tellus T 32
Texaco	Rando HDZ 32
Union	Unax AW-WR-32
Amsoil	AWH 15032
Sunvis	Low Pour H/032-product code 19300

Tool Connecting Procedures

1. Stop the engine before connecting the tool and or hoses to the power unit, and when switching hoses or tools.
2. Turn the hydraulic on/off valve to the off position before starting the engine.

Make sure all hoses are connected for correct flow direction to and from the tool being used.

When routing hose in the work area, position them where personnel will not be at risk of tripping over them where vehicles can run over the hoses. Do not lay hose over sharp objects.



WARNING Pressurized fluid escaping from a damaged hose can penetrate the skin and be injected in the body causing injury or death.

Do not pull on hoses to drag the power unit or tool.

Connecting Hoses

1. Wipe quick couplers with a clean lint free cloth before connecting them.
2. Depressurize the system.
3. Allow system and hydraulic fluid to cool if too hot to handle.
4. Securely connect the return (tank “R”) hose from the power source to the tool.
5. Securely connect the supply (pressure “P”) hose from the power source to the tool.

It is recommended that you connect the return hoses first and disconnect last to minimize or avoid trapping pressure within the tool.

When connecting the quick couplers, the flow should run from male coupler to the female coupler. The female coupler on the tool is the inlet. Quick couplers are marked with a flow direction arrow.



WARNING Pressurized fluid escaping from a damaged hose can penetrate the skin and be injected in the body causing injury or death.

Do not pull on hoses to drag the power unit or tool.

Note: When possible, connect the free ends of uncoupled hoses to prevent build up in the hoses. The sun can also increase pressure in the hoses and make connecting them difficult.

Disconnecting Hoses

1. Stop the hydraulic power source.
2. Depressurize the system.
3. Allow system and hydraulic fluid to cool.
4. Disconnect the supply (pressure) hose to the power source (pressure port) from the tool (IN port).
5. Disconnect the return (tank) hose to the hydraulic power source (return port) from the tool (OUT port).
6. To prevent contamination, always install dust caps over the hydraulic ports of the tool when disconnected.

Section 3: Tool Operation

Personal Protective Equipment



Before operating this machine, make sure that all general safety precautions are observed, and that proper personal protective clothing is worn as described below.

At a minimum, operators should wear the following Personal Protective Equipment:

1. Safety Glasses
2. Hearing Protection
3. Hard Hat
4. High Visibility Safety Vest
5. Leather Work Gloves (outside the cab)
6. Steel Toed Safety Shoes

Spring Loaded Handles

The Hydraulic Spike Driver is equipped with spring loaded handles for operator comfort when operating thus dampening vibration and decreasing fatigue. This handle also controls operation of the control valve cartridge.

- Press down on the handles to open the control valve and begins operation.
- Pull up to close the hydraulic control valve, stopping operation.

Spring loaded handles reduce vibration and operator fatigue.

The spring-loaded handle extends the control valve spool to the OFF position thus prevents accidental starting of the tool.

Operation

1. Connect the pressure and return hoses to the hydraulic power source and start power motor.
2. Grasp both handles firmly, place the ram end on the spike head and press the handle toward the spike driver, activating the tool.

Always hold the tool with both hands to maintain control.

3. To stop the Hydraulic Spike Driver, pull up on the handles.

When the fastener contacts the surface of the material being fastened, impact time is predicated by the number of strokes required to drive a spike into a wooden tie

Shut-Down Procedures

1. Stop the Hydraulic Spike Driver with the spring loaded handle to close the valve.
2. Shut down the hydraulic power source.
3. Disconnect the hydraulic hoses from the spike driver.
4. Remove the tool from work area.
5. Prepare the unit for transport as outlined in transportation and handling.

Section 4: Maintenance

It is highly recommended to practice regular check-ups and maintenance in accordance with the usage frequency to keep your tool in better condition and reduces total running costs.



WARNING

Do not perform maintenance on the machine while the hydraulic power source motor is running or when hoses are connected.

All maintenance must be done with the tool disconnected from the power source.

Cleaning and Maintenance Recommendations

- Wipe all external surfaces after each use with a clean, lint free cloth to remove surface contaminants from the tool.
- Store all tools in an enclosed area to prevent weather from contaminating their systems.

Safety Devices

When maintenance is complete, make sure the following:

- The hydraulic control valves are operable.
- The hydraulic quick couplers and hoses are safe to use.

Storage Preparation

- Cover male and female hose whips.
- Store in the upright position. Secure tool to prevent it from being knocked over.
- Store the machine on a smooth level surface.
- The tool should be stored in a cool, dry environment which is not subjected to rapid temperature changes.

Daily



WARNING

Do not attempt to locate hydraulic leaks by feeling around hoses and fitting with hand. Pin-Hole leaks can penetrate the skin.

- Wipe all tool surfaces, fittings, and couplings free of grease, dirt, and foreign materials.
- Inspect the tool, hydraulic system, hoses, and fittings for signs of leaks, cracks, wear, and/or damage. Replace if necessary.
- To prevent contamination, always install dust caps over the hydraulic ports when disconnected.
- Inspect machine for damage and wear, replace as required.

Monthly

- Perform a detailed inspection of the systems hoses and fittings according to the hydraulic hose operator's manual and as stated in SAE standard j1273, May 1989 or latest revision.

Replace the hoses and/or fittings if necessary.

Trouble Shooting

The following chart can be used as guide to correct any problem you may be experience with the Hydraulic Spike Driver:

To determine the problem in operation of the spike driver, always check that the hydraulic power source is supplying the correct hydraulic flow and pressure to the tool as listed in the table.

- Be sure you are using an accurate flowmeter.
- Check the flow with the hydraulic fluid temperature at least 80° F/27° C.
- Always check the power source and hoses before disassembling the spike driver.

Problem	Possible Cause	Solution
Tool will not run.	Power source.	Check power source flows and pressure (5-10 gpm/20-38 lpm @ 1500-2000 psi 100-400 bar).
	Coupler or hoses.	Check for /remove obstruction.
	Flow control spool not fully shifted.	Shift spool to on or off position.
	Mechanical failure.	

Section 5: Parts and Service Support

Telephone and web-based technical support is available for current production models through our Technical Service Department. Service Manuals and limited technical support may be available for models that are no longer in production.

Telephone and E-mail Technical Support

Telephone and e-mail technical support is available on normal U.S. business days from 8:00 AM to 5:00 PM U.S. Central Time Zone (GMT +6 (+5 Daylight Savings Time)). Contact us at:

Phone: (262) 637-9681

E-mail: techserv@racinerailroad.com

Non-Warranty Technical or Field Service Support

Depending upon the circumstances and availability of technical service personnel, we may provide technical assistance and/or field service support, *at the customer's expense*, to assist in the correction of non-warranty related problems. Contact our Technical Service Department to coordinate Non-Warranty Technical or Field Service Support.

Warranty Technical or Field Service Support

Depending upon the circumstances and availability of technical service personnel, we may provide technical assistance and/or field service support, *at no charge to the customer*, to assist in the correction of warranty related problems. Contact our Technical Service Department to coordinate Warranty Technical or Field Service Support.

Warranty Parts & Service

Warranty parts and service are coordinated through our Technical Service Department.

Warranty Parts Claims

Material claimed to be defective must be returned to our factory for evaluation. Defective materials will be replaced, or your account will be credited if replacement materials have already been purchased. Please contact our Technical Service Department at the address provided below if you have any questions or problems.

Warranty Service Support

Depending upon the circumstances and availability of technical service personnel, we may provide technical assistance and/or field service support, at no charge to the customer, to assist in the correction of warranty related problems. Contact our Technical Service Department at the address provided below to coordinate Warranty Technical or Field Service Support.

Hydraulic Spike Driver Assembly and Parts List

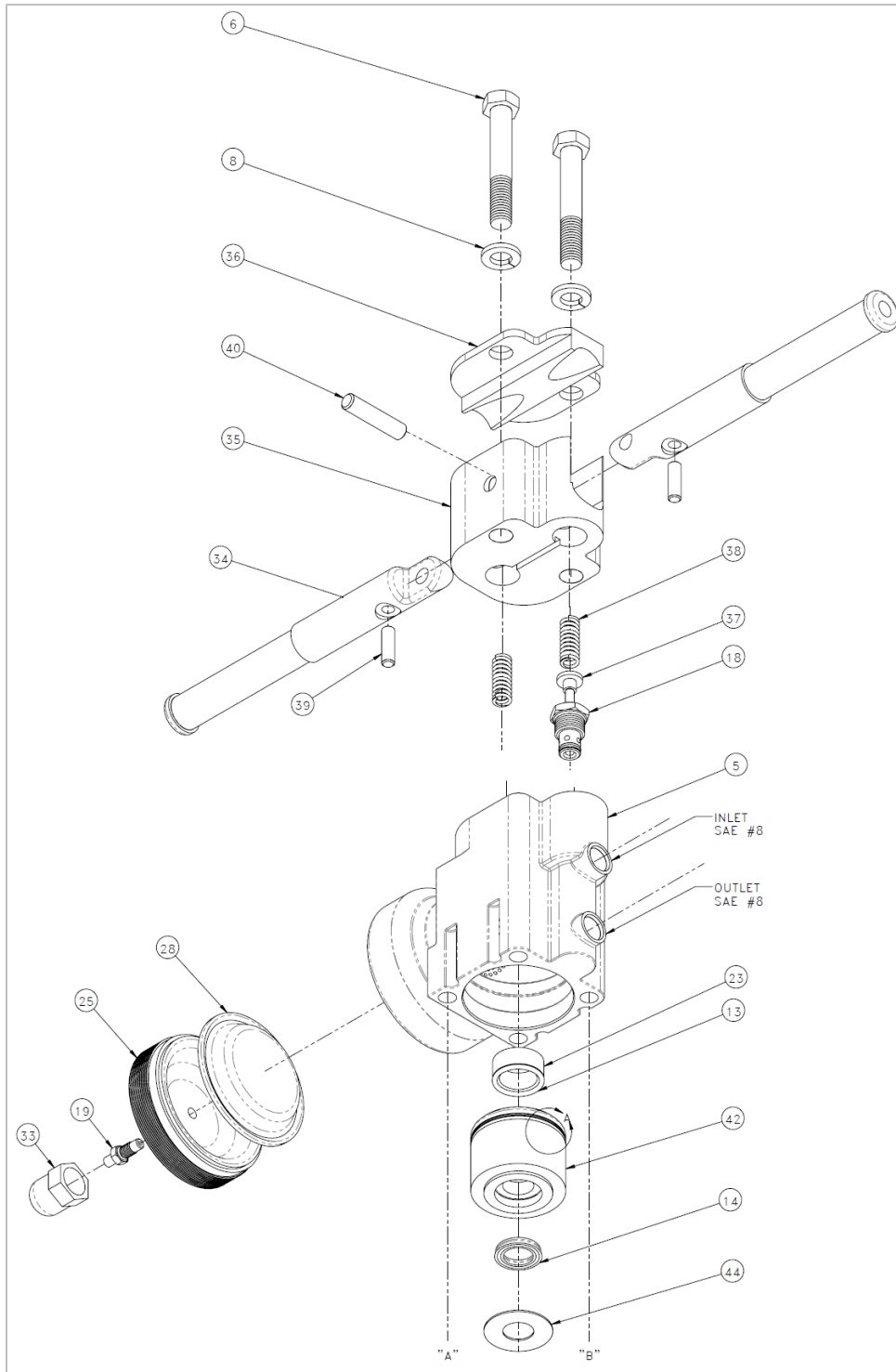

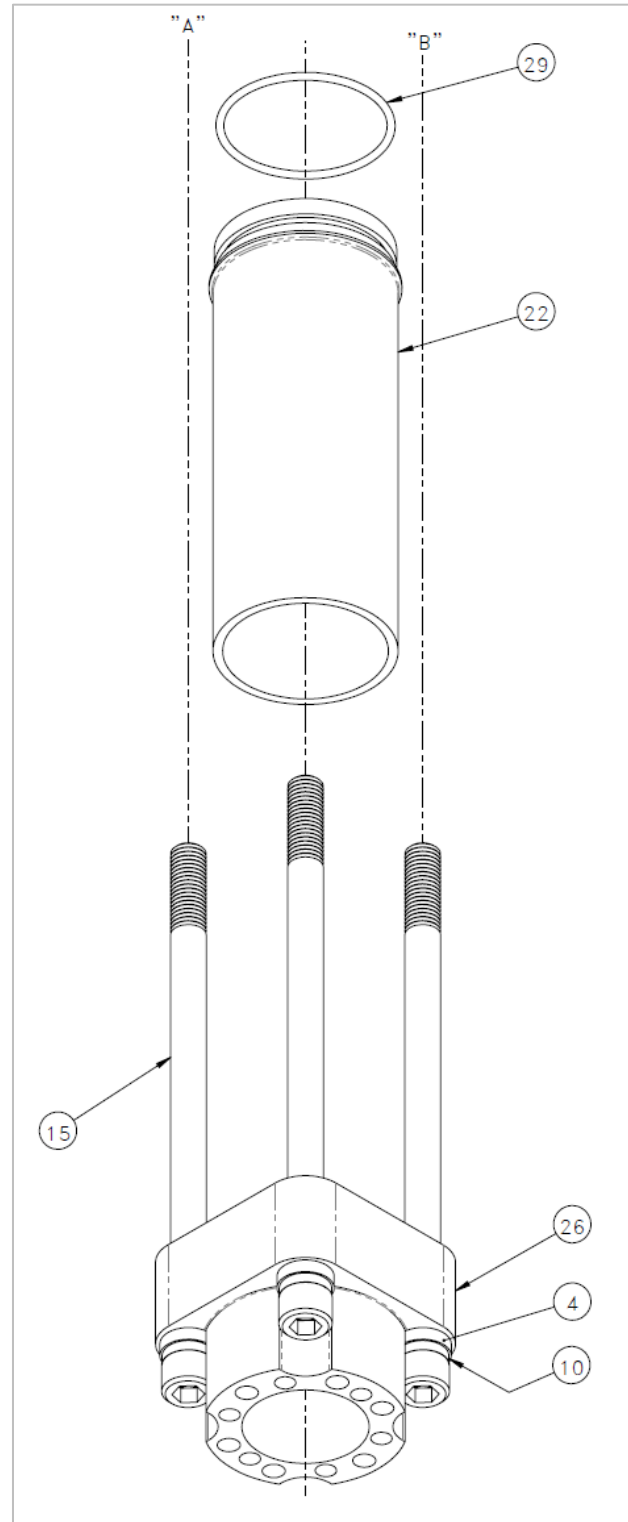
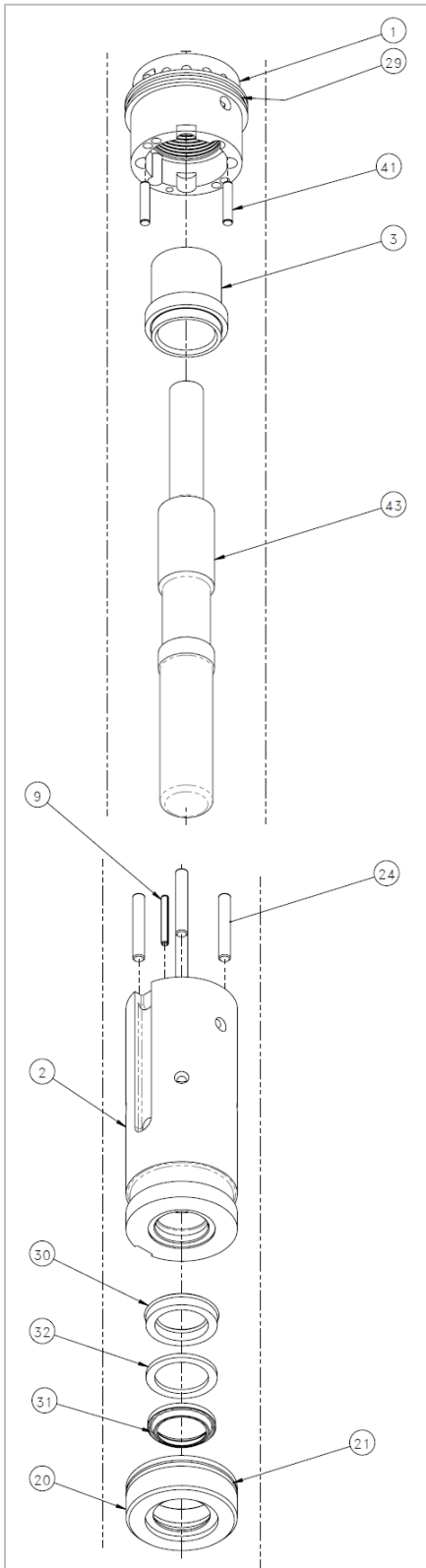

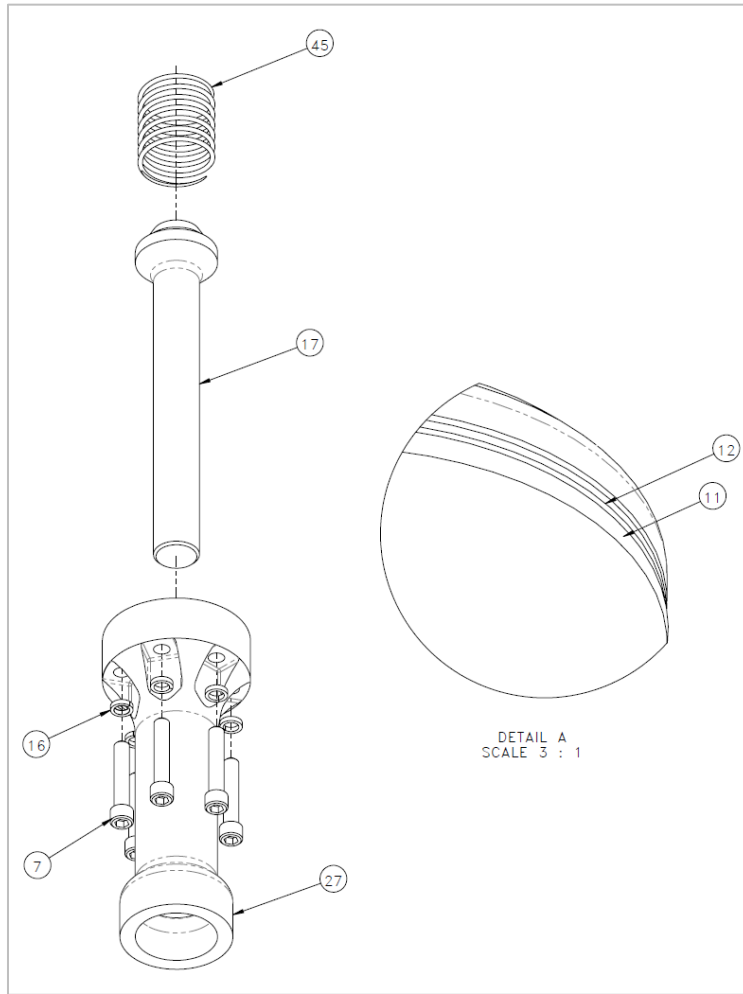

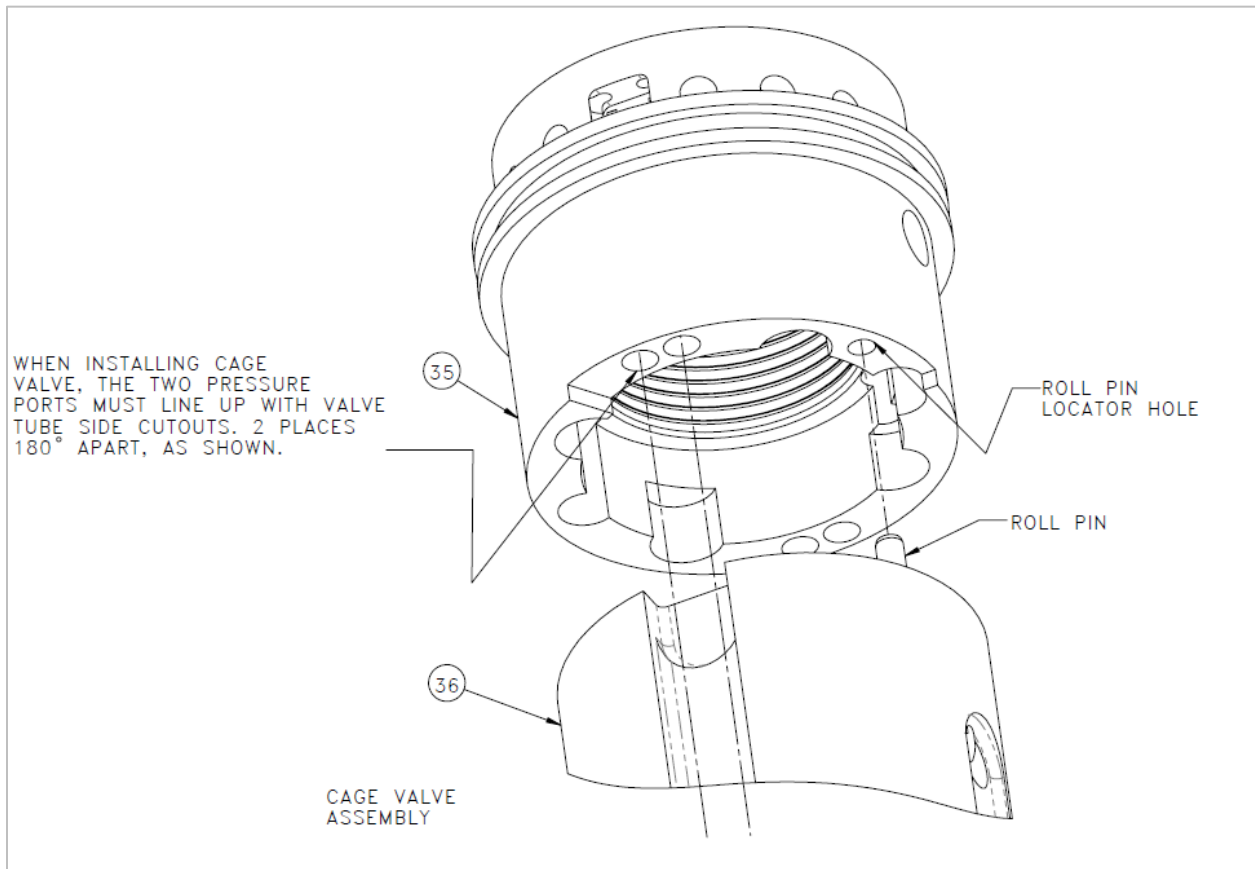

NO.	QTY.	DESCRIPTION	PART NO.
1	1	VALVE, CAGE	316326
2	1	TUBE, VALVE	316327
3	1	BUSHING	321602
4	4	SPACER, TIE ROD	323122
5	1	BLOCK, VALVE	323123
6	2	SCR, HEX: .62-11 X 4	400766
7	6	SCR, SOC: .38-16 X 2	400806
8	2	WASHER, LOCK: .62 SPLIT	400910
9	1	PIN, ROLL: .19 X 1.5	404012
10	4	WASHER, LOCK: .62 HIGH COLLAR	470284
11	1	O-RING, 2.484 ID X .139 W	470316
12	1	RING, BACKUP: 2.51 ID X 2.74 OD X .04 W	470317
13	1	O-RING, 1.234 ID X .139 W	470494
14	1	SHAFT, SEAL: .875 ID	476328
15	4	SCR, SOC: .62-11 X 11	491834
16	6	WASHER, LOCK: .38 SPLIT HIGH COLLAR	10000145
17	1	ANVIL	10000172
18	1	CARTRIDGE, CONTROL VALVE	10000247
19	1	VALVE, ACCUMULATOR FILL	10000298
20	1	RETAINER, LOWER SHAFT SEAL	10000373
21	1	O-RING, 2.62 I.D. X 2.88 O.D. X .12 W	10000374
22	1	TUBE, LOWER	10000375
23	1	FILTER	10000377
24	4	PIN, DOWEL: .31 X 2	10000379
25	1	CAP	10000382
26	1	ADAPTER, END CAP	10000392
27	1	CAP, END	10000393
28	1	DIAPHRAGM	10000395
29	2	O-RING, 2.88 I.D. X 3.12 O.D. X .12 W	10000396
30	1	SEAL, SHAFT: 1.38 ID	10000400
31	1	WIPER, ROD: 1.375 ID	10000401
32	1	WASHER, FLT: 1.40 ID ALUM	10000404
33	1	CAP, ACCUMULATOR FILL	10000419
34	2	HANDLE	10000434
35	1	SPACER	10000435
36	1	CAP	10000436
37	1	ADAPTER, VALVE STEM	10000437
38	2	SPRING, COMPRESSION	10000439
39	2	PIN, DOWEL: .38 X 1.25	10000440
40	1	PIN, DOWEL: .5 X 2.25	10000441
41	2	PIN, DOWEL: .25 X 1.25	10000452
42	1	RETAINER, UPPER SHAFT SEAL	10000460
43	1	HAMMER	10000461
44	1	WASHER, SEAL	10000463
45	1	SPRING, COMPRESSION	26000320
46	2	HOSES, WHIP	26002503

Section 6: Warranty Terms and Conditions

Warranty Period

Each new machine and new parts of our manufacture are warranted against defects in material and workmanship for one year from the date of shipment from our factory.

When contacting customer service for factory parts, service or warranty support please provide the:

- Racine Railroad Products Model
- Serial Number
- Any locally assigned identification

Vendor Parts Warranty Period

Other equipment and parts used, but not manufactured by Racine Railroad Products, Inc., are covered directly by the manufacturer's warranty for their products.

Warranty Parts and Service

We will repair or replace, without charge, F.O.B. factory, Racine, Wisconsin, USA, any part Racine Railroad Products manufactures which is proven to be defective during the warranty period.

Material claimed defective must be returned, if requested, to the factory within 30 days from the date of the claim for replacement. Ordinary wear and tear, abuse, misuse, and neglect are not covered by this warranty. Depending upon the circumstances, we may provide technical assistance and/or technical service support, without charge, to assist in the correction of warranty related problems.

Non-Warranty Parts and Service

Material damaged through normal wear and tear, abuse, misuse and/or neglect are not covered by our warranty and should be ordered directly from our Customer Service.

Note: Parts for models that are no longer in production may not be available.

Non-Warranty Parts Orders

When placing a parts order please provide the following information:

- Company Name and Billing Address
- Purchase Order Number and Issuing Authority
- Shipping Address
- Special Handling Instructions
- Contact Phone Number
- Machine Model and Serial Number
- Part Numbers and Quantities Being Ordered

Note: *Please use Racine Railroad Products part numbers when ordering parts.* Racine Railroad Products part numbers are shown in the parts lists and drawings of this manual and have only six (6) numbers.

Any part number with other than six numbers (e.g., contains alpha-numeric characters) is a Vendor Part Number and **not** a Racine Railroad Products part number